



# SPeDIP 2021

SEMINAR PENYELIDIKAN DAN INOVASI DALAM PENDIDIKAN 2021  
PERINGKAT KEBANGSAAN



KUCHING

## 3 IN 1 FUEL INJECTOR TESTING

1. MUHAMMAD FATTAH RIZQIN BIN HASHIM

2. FADZILAH BIN SUHALI

### PRODUCT DESCRIPTION

- FUEL INJECTOR TESTING : Injector is an important part of modern engine. Injector that is clog or not functioning well will make the engine not working well such as hard to start, shacking during idling, more fuel consumption, lack of respond.
- There is 3 important thing for maintenance an injector
- Cleaning: Cleaning the injector is to remove all the carbon and clogged.
- Spray testing: Spray is to ensure the spray pattern is good condition.
- Fuel measure: All type of engine required a balance fuel distribution to each cylinder to smoother the engine idling and respond.
- With this FUEL INJECTOR TESTING that we innovate, it will make anyone can do it them self for maintenance there car injector or any engine with EFI.

### APPLICATION

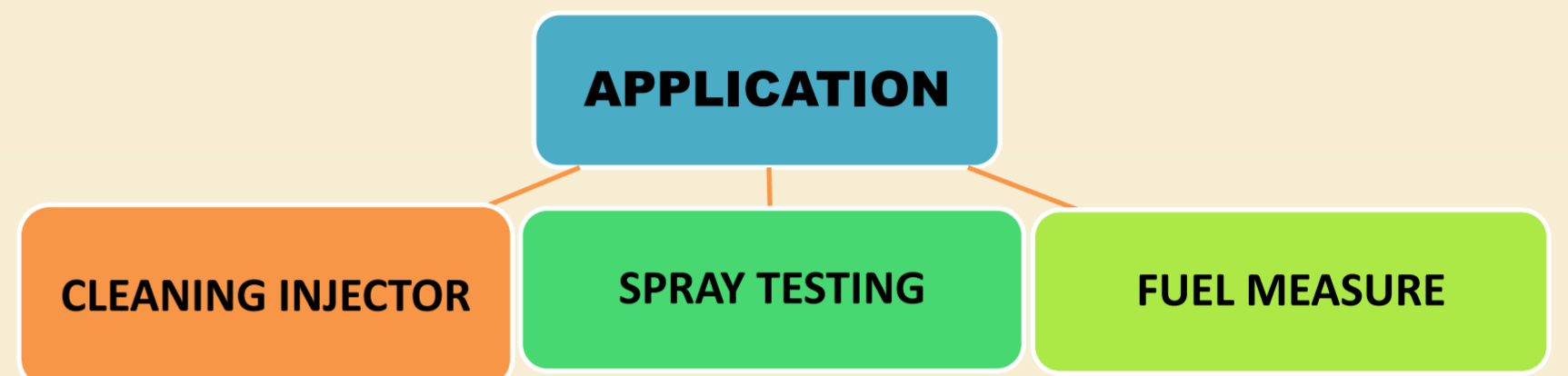

### OBJECTIVES

Focus on friendly user & maintaining:

- Easy and basic learning on injector maintenance.
- Compact and portable.
- Easy to conduct and friendly used.
- Cheaper then industrial machine.
- High market potential.

### MARKET POTENTIAL

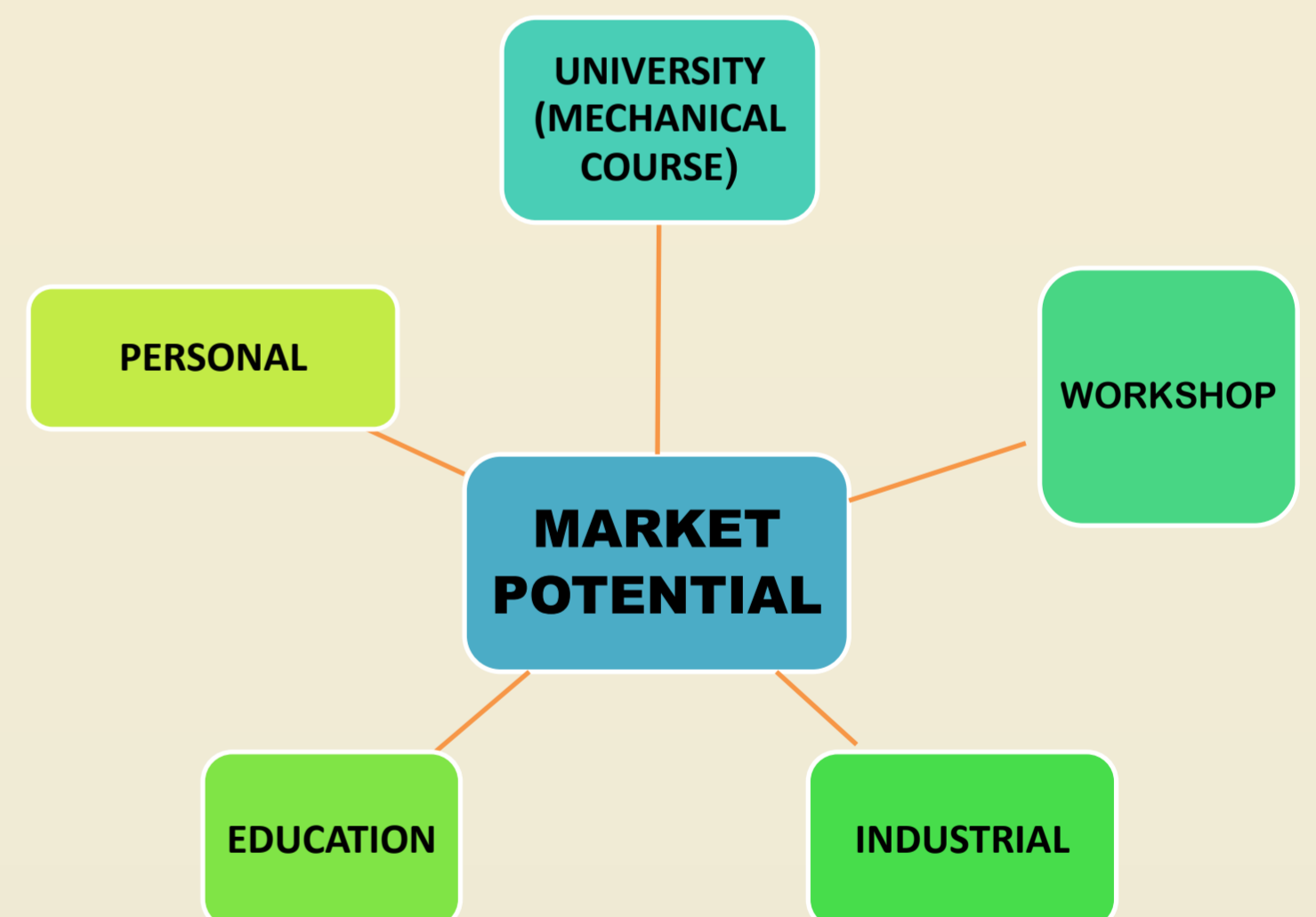

### DIAGRAM

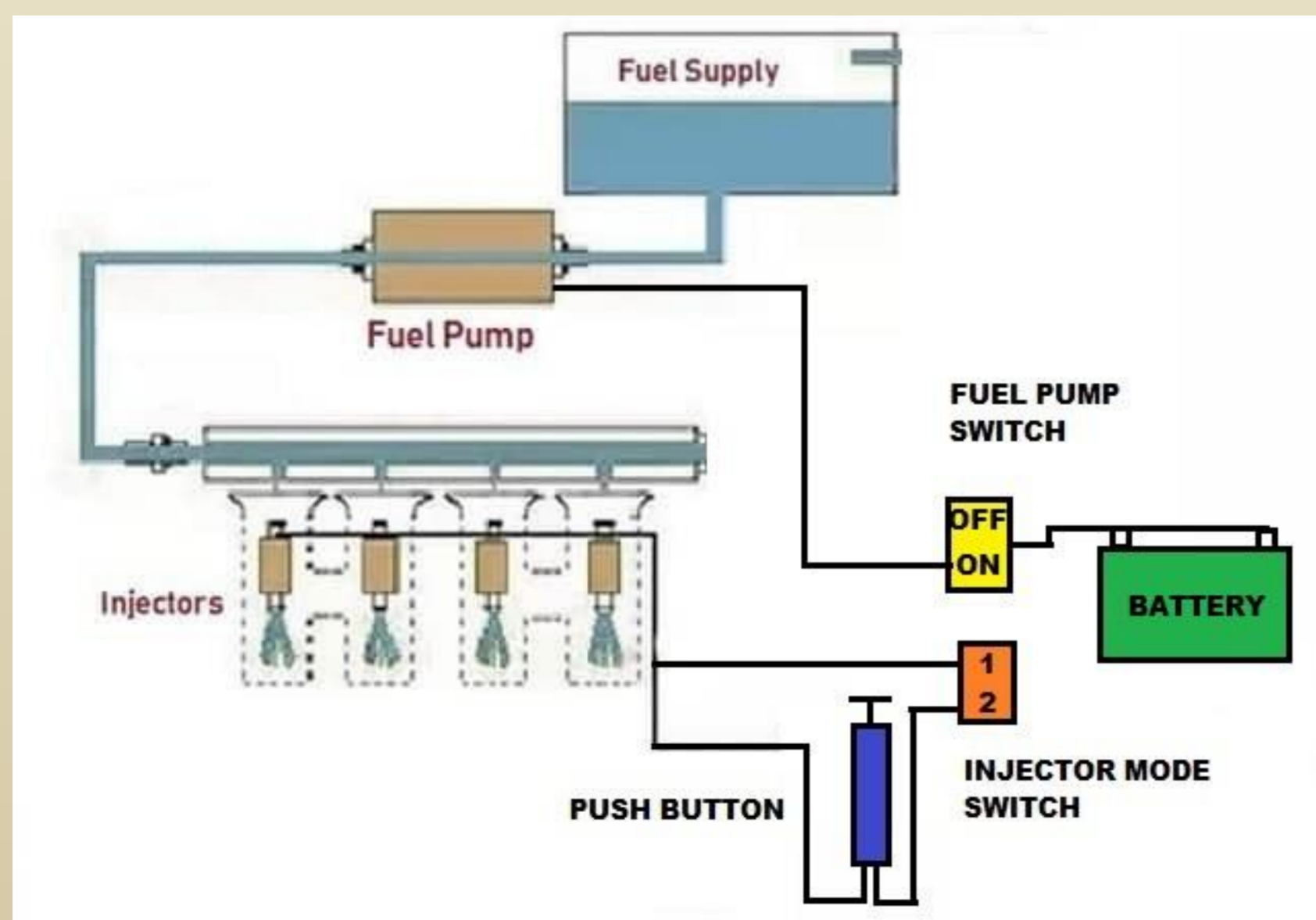

### PROJECT PICTURE

